

MISSION/DIRAC CLASS

ENTERED SERVICE: 2248

OVERVIEW: Originally conceived as a small, multi-purpose starship which could be quickly (and economically) reconfigured for a variety of missions, the *Mission* Class exceeded its designers wildest dreams. The ship can be reconfigured almost at-will with “break-down: internal partitions bulkheads and easily-reconfigured utility connections. In her “bare-bones” cargo configuration, the *Mission* Class can accommodate up to 675 cubic meters of bulk or containerized cargo or up to 100 passengers in an emergency (evacuation) configuration.

Because they were built in great numbers and are both economical and easy to maintain, the *Mission* Class remain in service throughout the 23rd and 24th centuries.

TM-378260-3
STAR FLEET TECHNICAL ORDER
AUTHENTICATED STARDATE 7612.13

TO-01:04:65

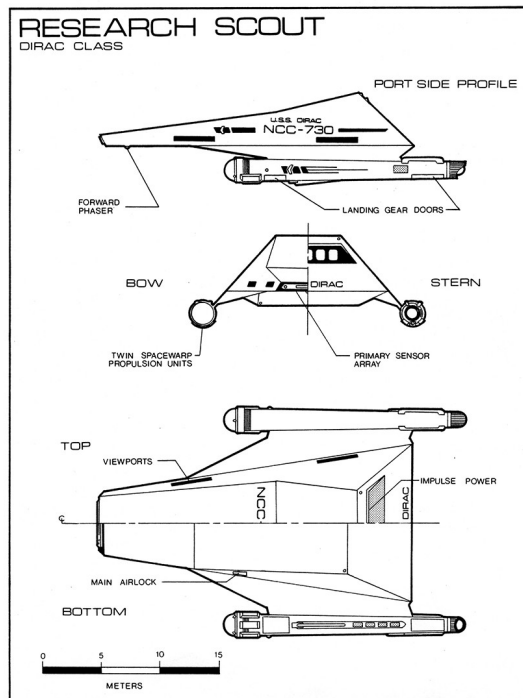

Ship Statistics:

Comms	6	Command	
Computers	6	Conn	1
Engines	6	Security	
Sensors	6	Engineering	1
Structure	7	Science	1
Weapons	6	Medicine	

Crew Complement: 9, up to 300 passengers
Maximum Speed: Warp 7 (Old Scale), 5.5 (NG)
Emergency Speed: Warp 9.5 (Old Scale), 7 (NG)
Refits: 0

TALENTS

None.

TRAITS Federation Starship, Ubiquitous.

SCALE: 2
Resistance: 2
Shields: --
Power: 3
Crew Support: 2

WEAPONRY:
 Phaser Bank, Versatile 2
 Tractor Beam: Strength 1

* Artwork The Mission ship first appeared in a number of FASA Star Trek RPG supplements.

S.S. BANTU WIND

ENTERED SERVICE: 2257

OVERVIEW: A “tramp freighter” operating on the fringes of Federation space, the *Bantu Wind* (Captain Simon Katanga, commanding) can usually be found wandering (semi-) aimlessly among the stay systems between (or near) Deep Space Four and Five, hawking a variety of wares, moving a bewildering array of goods, and doing whatever jobs are to be found.

Katanga and his crew¹ are a rough-and-tumble lot, gathered and recruited from a variety of spaceports reputable and not, and are frequently (and inaccurately) derided as pirates. Katanga may lie, cheat, steal, and swindle the unwary or the foolhardy, but neither will they simply appropriate what they want at gunpoint.

TM/STW280-3
STAR FLEET TECHNICAL ORDER
AUTHENTICATED STARDATE 7612.13

TO:01:04:65

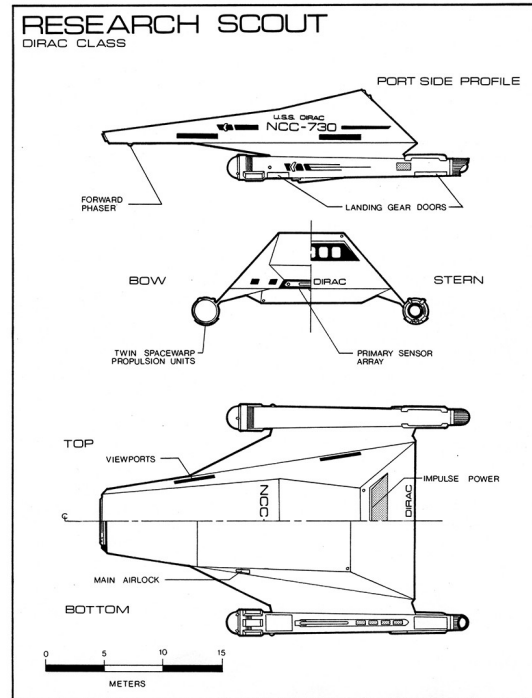

Ship Statistics:

Comms	7	Command	2	SCALE:	2
Computers	6	Conn	3	Resistance:	3
Engines	7	Security	2	Shields:	9
Sensors	6	Engineering	3	Power:	3
Structure	7	Science	3	Crew Support:	2
Weapons	8	Medicine	2		

Crew Complement:	9, up to 300 passengers	WEAPONRY:	Phaser Bank 4▲, Versatile 2
Maximum Speed:	Warp 7 (Old Scale), 5.5 (NG)		Tractor Beam: Strength 1
Emergency Speed:	Warp 9.5 (Old Scale), 7 (NG)		
Refits:	4		

TALENTS

Improved Hull Integrity The ship's hull has been reinforced to hold together better under stress and damage. The ship's Resistance is increased by 1.

TRAITS Federation Starship, Ubiquitous. Long-serving.

¹ Captain Katanga and his crew are considered “Talented” as per pg 301 of the Core Rulebook.

* Artwork The Mission ship first appeared in a number of FASA Star Trek RPG supplements.

U.S.S. FRAM *

ENTERED SERVICE: 2253

OVERVIEW: USS *Fram* was commissioned in 2253 for mid-range planetary cartography and survey work with Starfleet Command's Materiel Services Division, and has spent most of her career search for and mapping suitable colony sites and resources needed for a modern warp-capable society.

A “working-class girl”, *Fram* would never see the fame or acclaim of a ship-of-the-line, but she has provided steady, reliable, and valuable service for over a hundred years. *Fram*'s only genuine claim to fame was her 2303 survey of the notorious Lima Sierra system, which sparked a still-unsettled debate about the system and its contradiction of prevailing theories on Orbital.

*Fram*¹ is currently configured for Scientific and Survey Missions.

Ship Statistics:

Comms	7	Command	2	SCALE:	2
Computers	8	Conn	3	Resistance:	2
Engines	6	Security	1	Shields:	8
Sensors	8	Engineering	3	Power:	6
Structure	7	Science	4	Crew Support:	2
Weapons	6	Medicine	2		

Crew Complement: 14, 51 passengers
Maximum Speed: Warp 7 (Old Scale), 5.5 (NG)
Emergency Speed: Warp 9.5 (Old Scale), 7 (NG)
Refits: 5

TALENTS

Dedicated Personnel (Science). The ship gains two additional Crew Support, which may only be used to establish Supporting Characters who are part of the Science department.

Modular Laboratories. *Fram* has a number of empty, multi-purpose compartments that can be converted to laboratories. At the start of an adventure, the crew may decide how the labs are configured, creating an Advantage to work performed within.

TRAITS Federation Starship, Long-serving

¹ Captain Amundsen and her crew are considered “Exceptional” per pg 301 of the [Core Rulebook](#).

* *Fram* is named for the research vessel used in expeditions to the Arctic and Antarctic regions by the Norwegian explorers Fridtjof Nansen, Otto Sverdrup, Oscar Wisting, and Roald Amundsen between 1893 and 1912. *Fram* sailed farther north (85°57'N) and farther south (78°41'S) than any other wooden ship.

Fram was designed and built by the Scottish-Norwegian shipwright Colin Archer and is preserved at the museum which bears her name in Oslo, Norway.

TM379560-3
 STAR FLEET TECHNICAL ORDER
 AUTHENTICATED STARDATE 7812.13

TO:0104:65

